

M2

FRA ANTAL TIL TAL

FORMÅL	MATERIALER	OPDELING AF ELEVER
At give eleverne forståelse for sammenhængen mellem mængder og tal/cifre. Samarbejde.	- 2 forskellige sæt opgavekort * Centicubes Evt.: - Talkort * Tal-terninger * Små terninger med øjne * Blyant og papir til hvert elevpar	Parvis.
Niveau I Kun antal Niveau II Enkle regnestykker med antal		TIDSFORBRUG 30-45 min.

INSTRUKTION:

- ☞ Skub borde og stole lidt rundt, så eleverne skal igennem en lille forhindringsbane for at komme hen til kortene. Gerne ved også at kravle under borde og gå rundt om stole.
- ☞ Kortene lægges på gulvet i den ene ende af lokalet.
- ☞ Parrene står i modsatte ende af lokalet.
- ☞ En elev fra hvert par begiver sig nu gennem forhindringerne for at hente et kort. Hun kan f.eks. kravle under/over, gå rundt om eller hoppe over borde, stole og tasker.
- ☞ Tilbage ved makkeren skal hun tælle/regne sig frem til antallet af figurer på sit kort og nu vise det ved hjælp af samme antal hop.
- ☞ Makkeren ser altså ikke kortet først, men følger opmærksomt med og tæller hoppene. Samme antal vises nu med centicubes og skrives evt. ned på et stykke papir for også at få selve tallet med.
- ☞ Når de bruger kortene på **niveau II** med regnestykker, kan du også vælge at bede dem om at vise begge led og facit i opgaven med centicubes og dernæst skrive det hele ned.

NB!

Brug evt. talterninger, talkort og små terninger med øjne til at lade eleverne at vise sammenhængen mellem antallet på et kort og et tal/ciffer, så de kommer i mål ad endnu flere veje.

Lav et vendespil ud af talkort og opgavekort fra niveau I, så der skal findes stik. Endelig kan de også selv lave nye kort og opgaver til hinanden på små kort.



ILLUSTRATION TIL

M2 – FRA ANTAL TIL TAL

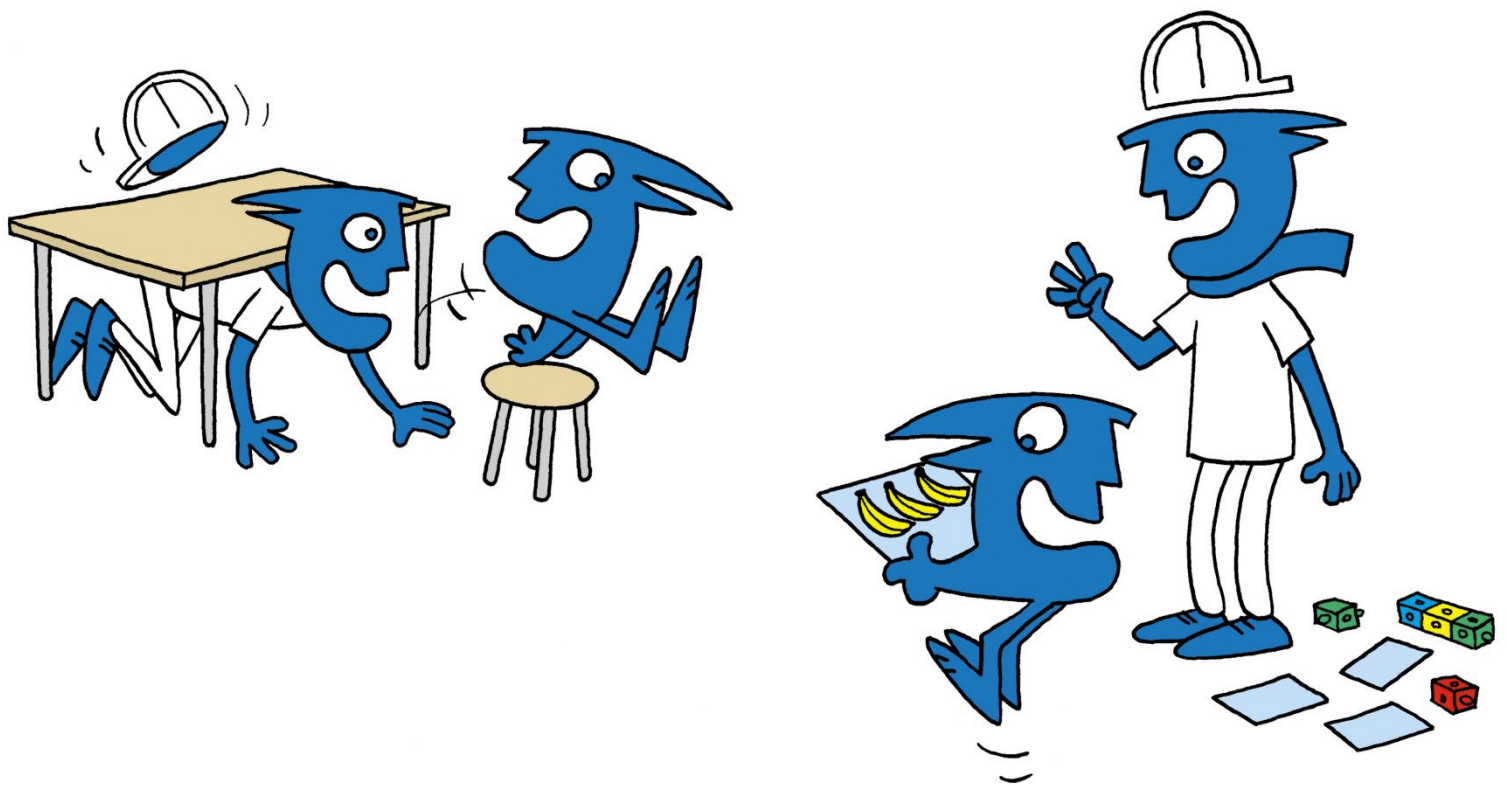
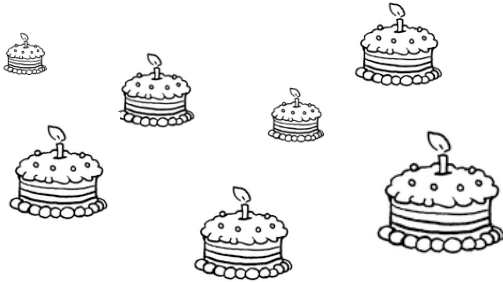
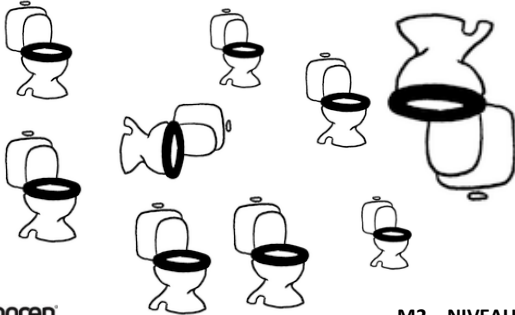
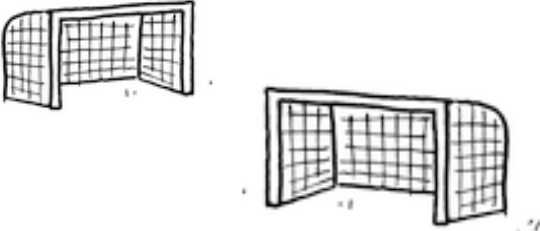

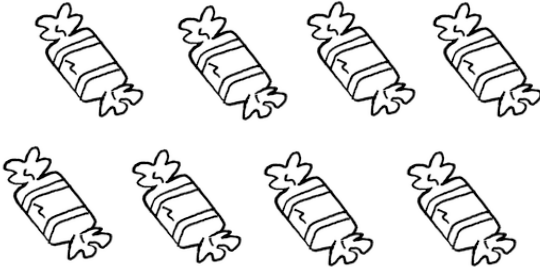

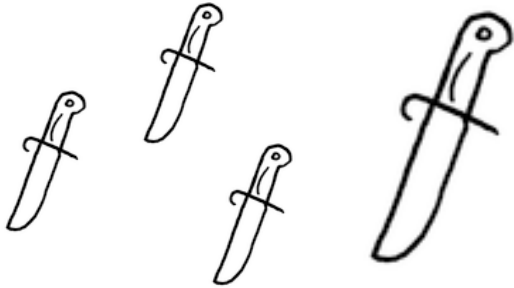
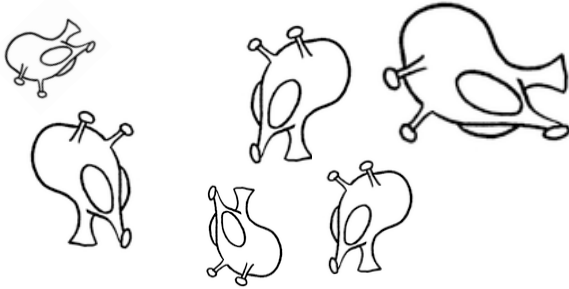
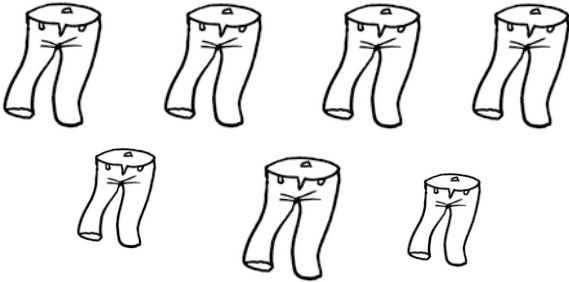
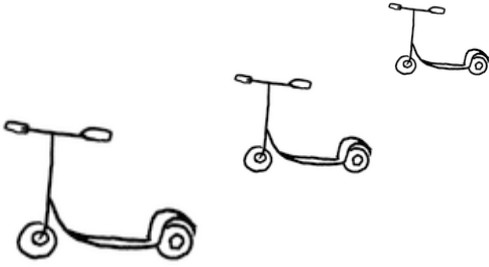
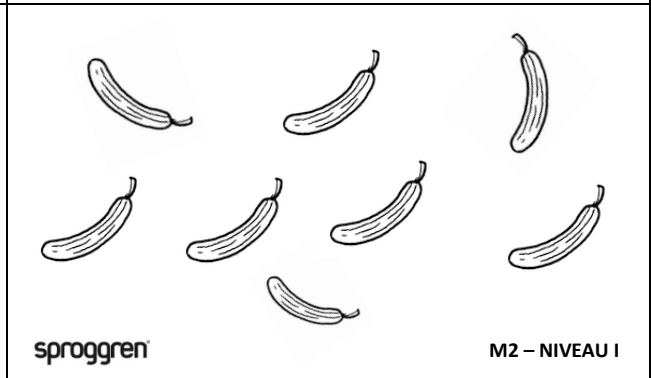
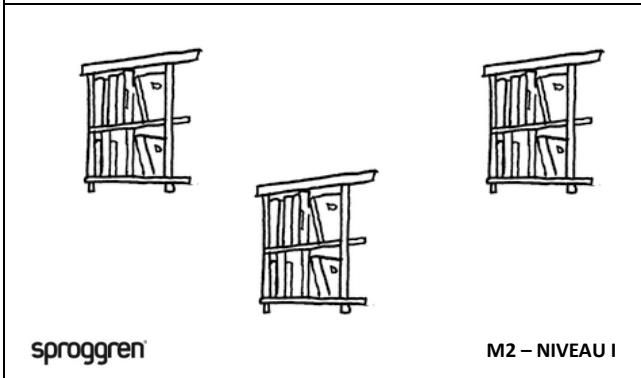
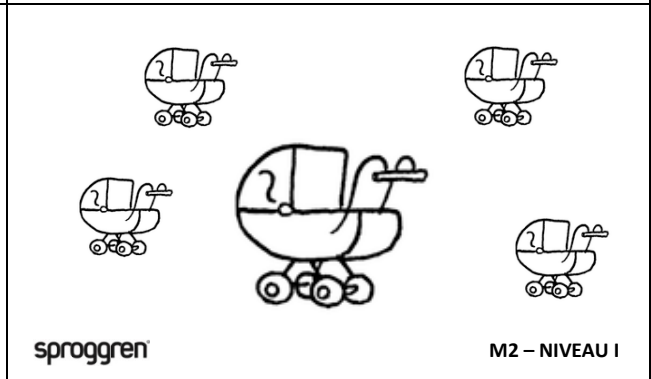
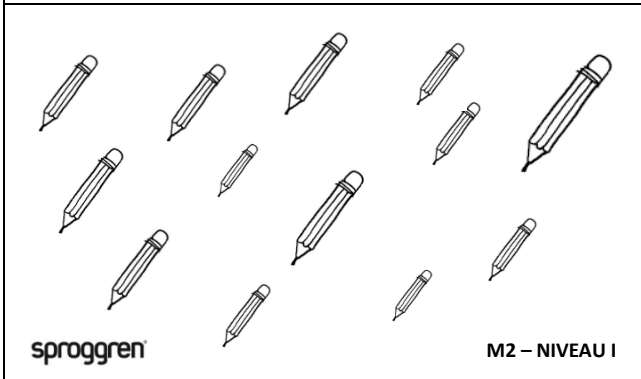
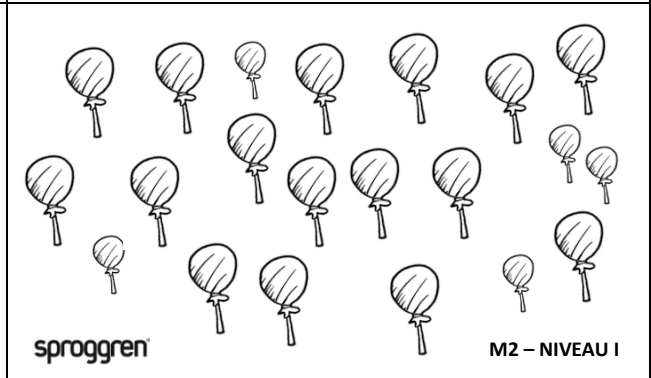
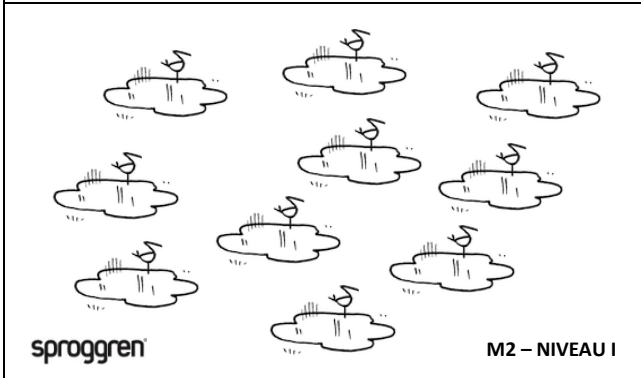
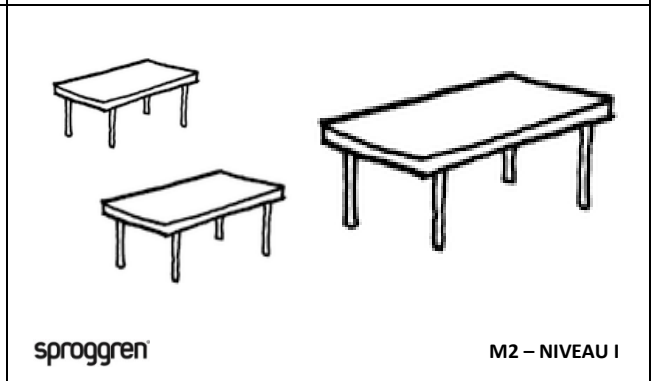
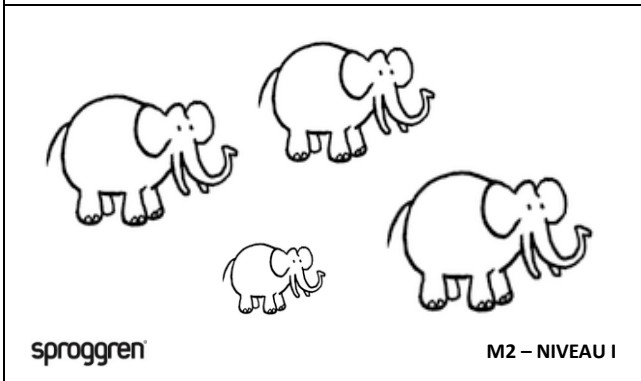
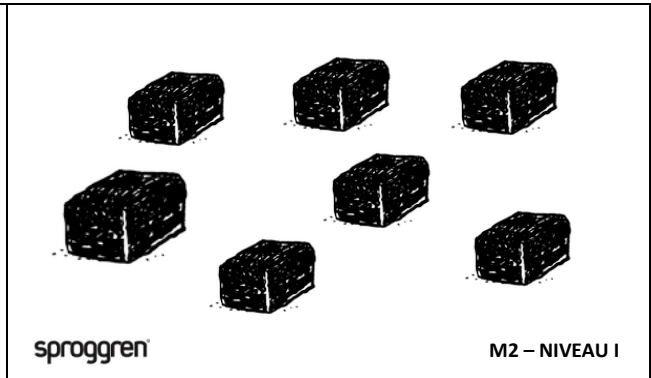
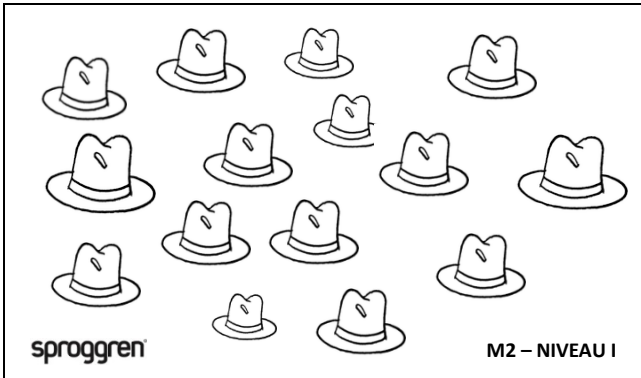
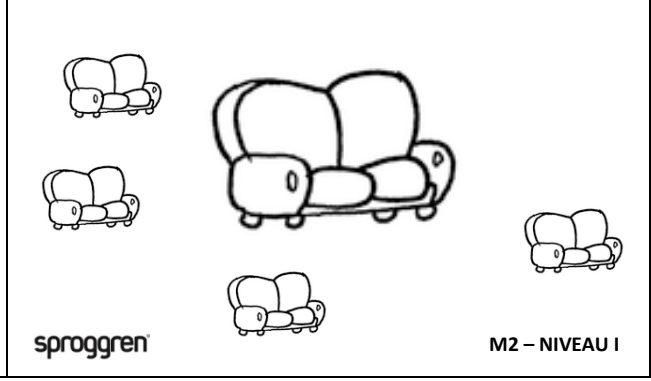
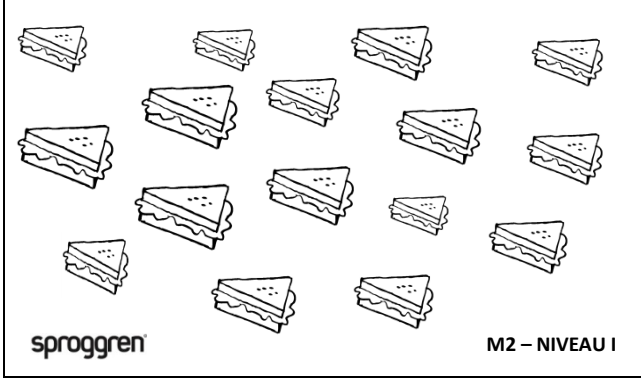
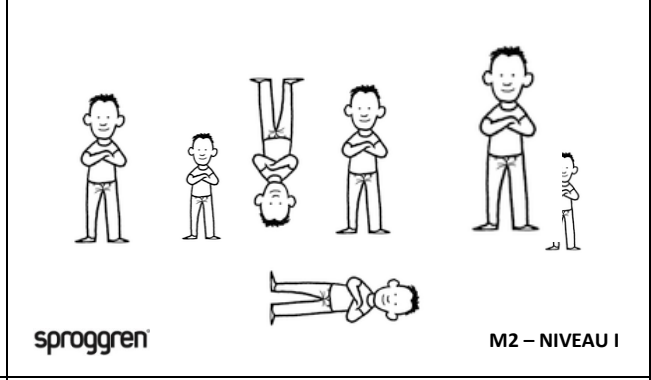
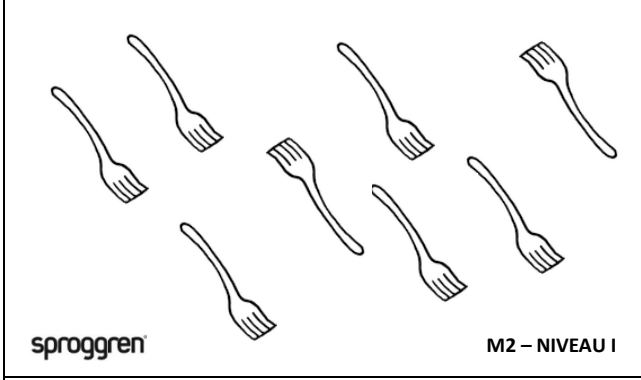
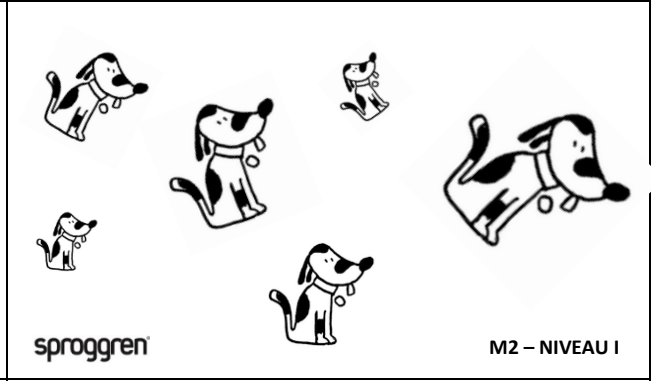
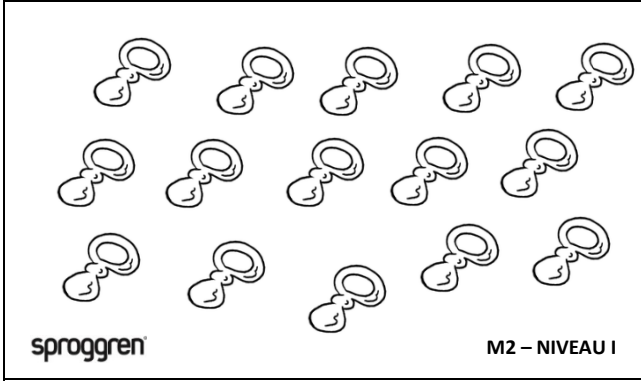
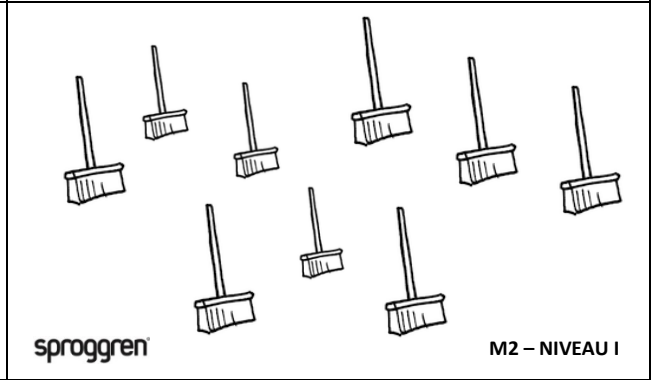
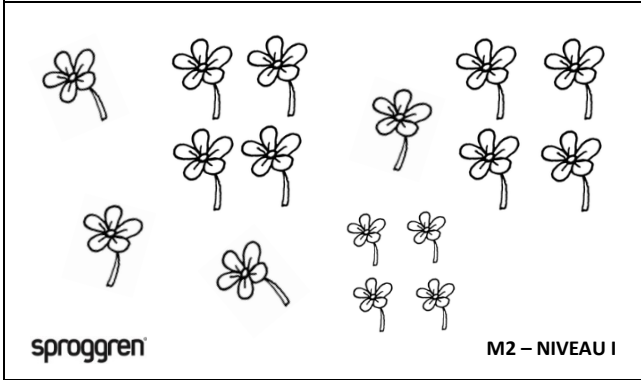
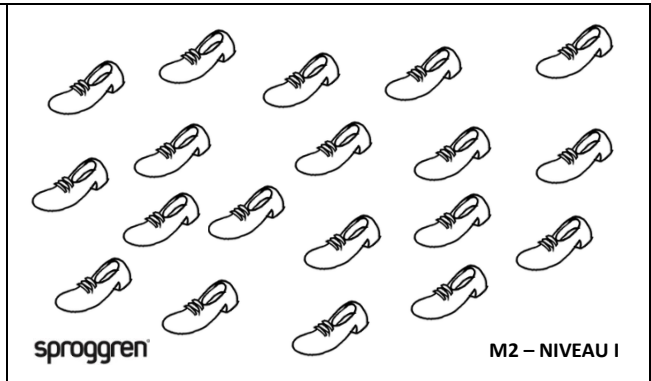
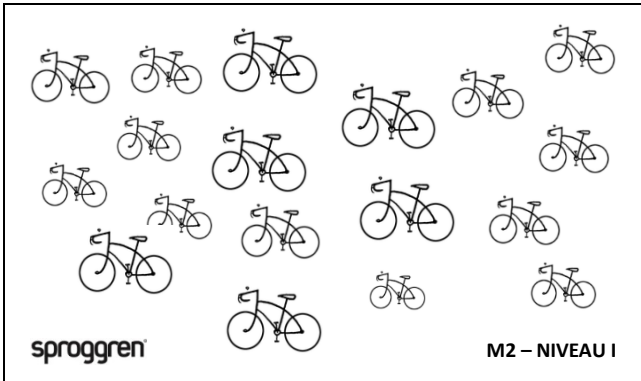
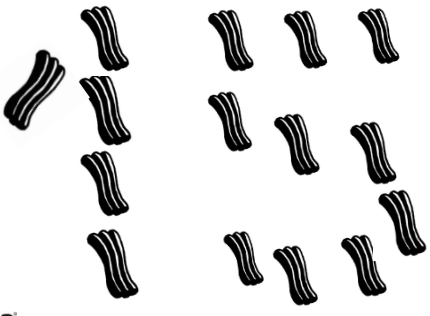
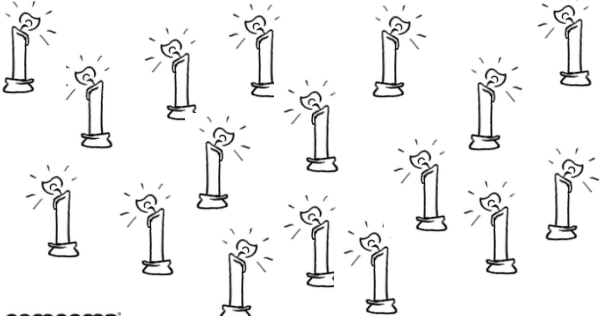
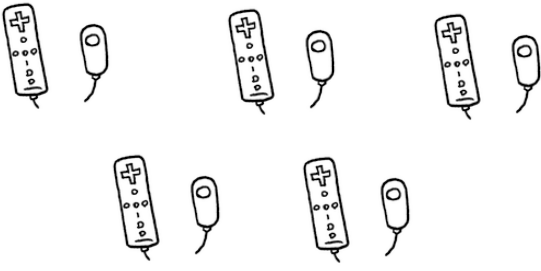
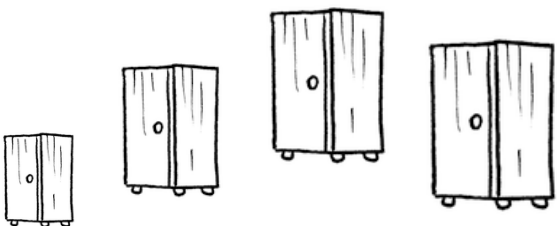
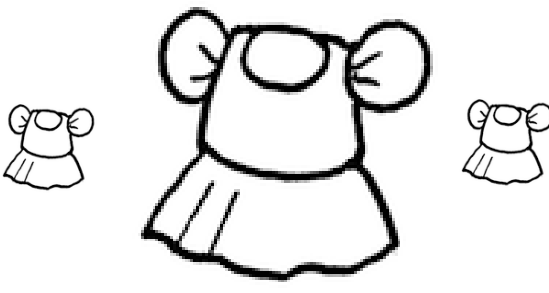

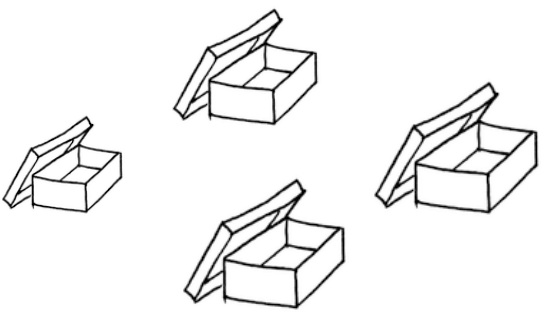
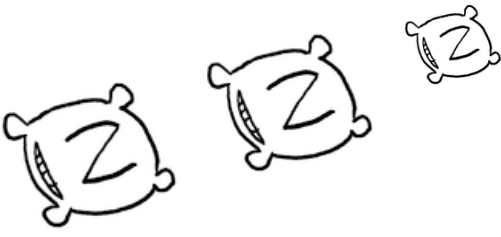

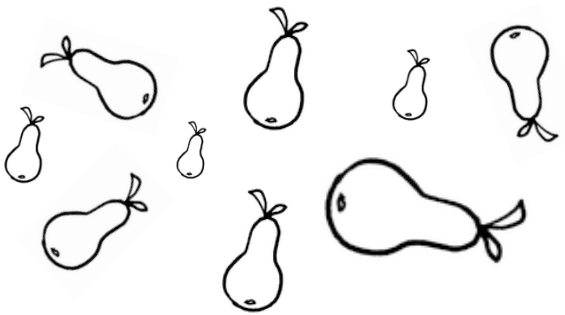

Illustration af www.saxoart.dk

 <p>sprogren[®] M2 – NIVEAU I</p>	 <p>sprogren[®] M2 – NIVEAU I</p>
 <p>sprogren[®] M2 – NIVEAU I</p>	 <p>sprogren[®] M2 – NIVEAU I</p>
 <p>sprogren[®] M2 – NIVEAU I</p>	 <p>sprogren[®] M2 – NIVEAU I</p>
 <p>sprogren[®] M2 – NIVEAU I</p>	 <p>sprogren[®] M2 – NIVEAU I</p>
 <p>sprogren[®] M2 – NIVEAU I</p>	 <p>sprogren[®] M2 – NIVEAU I</p>





 <p>sproggen® M2 – NIVEAU I</p>	 <p>sproggen® M2 – NIVEAU I</p>
 <p>sproggen® M2 – NIVEAU I</p>	 <p>sproggen® M2 – NIVEAU I</p>
 <p>sproggen® M2 – NIVEAU I</p>	 <p>sproggen® M2 – NIVEAU I</p>
 <p>sproggen® M2 – NIVEAU I</p>	 <p>sproggen® M2 – NIVEAU I</p>
 <p>sproggen® M2 – NIVEAU I</p>	 <p>sproggen® M2 – NIVEAU I</p>

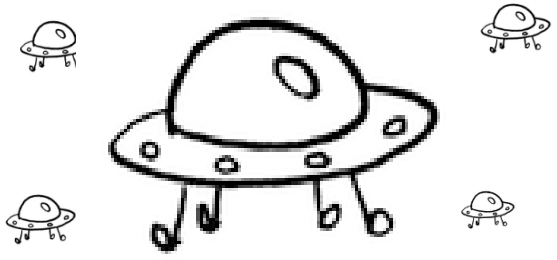

sprogren® M2 – NIVEAU I

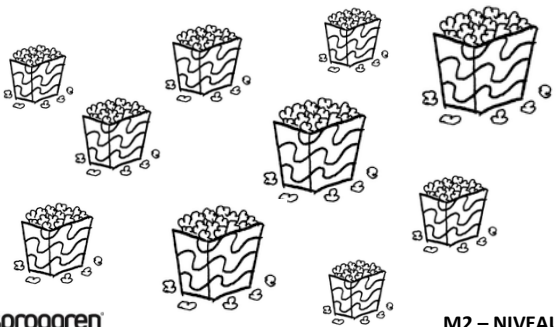

sprogren® M2 – NIVEAU I

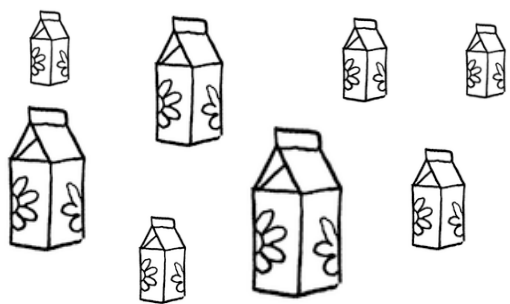

sprogren® M2 – NIVEAU I

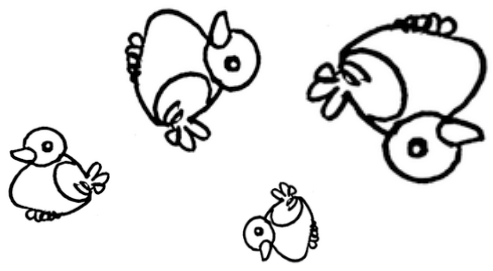

sprogren® M2 – NIVEAU I

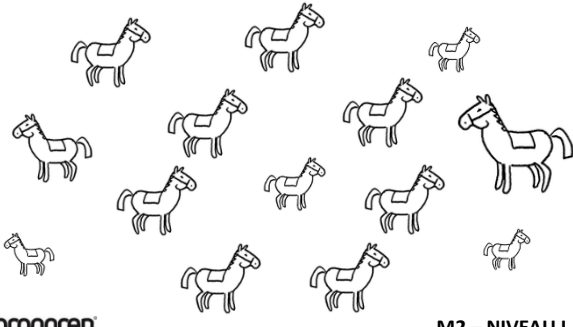

sprogren® M2 – NIVEAU I



sprogren® M2 – NIVEAU I

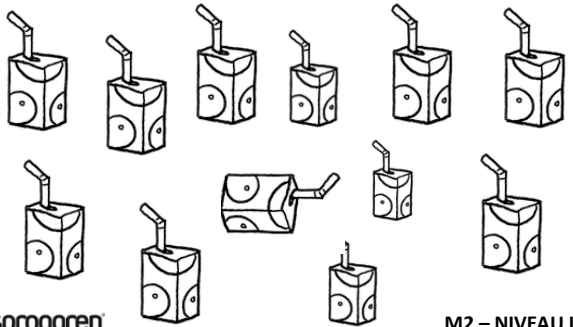

sprogren® M2 – NIVEAU I

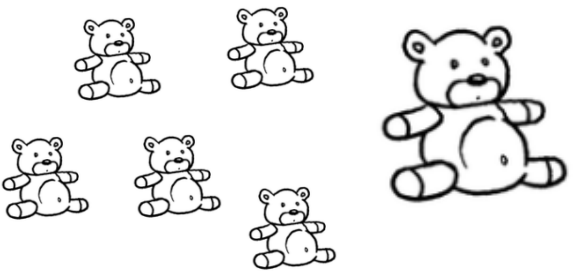

sprogren® M2 – NIVEAU I

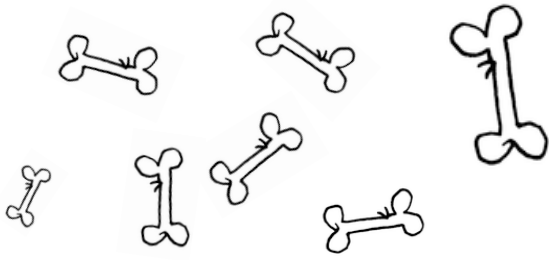

sprogren® M2 – NIVEAU I

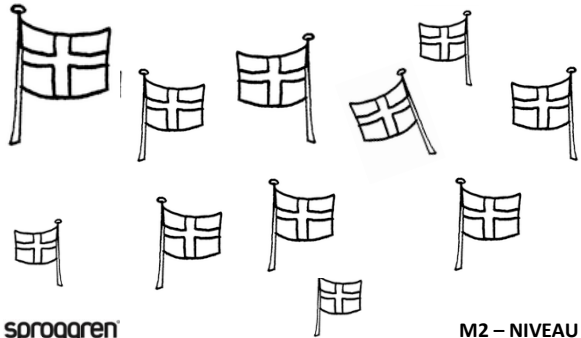

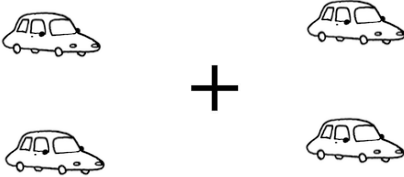
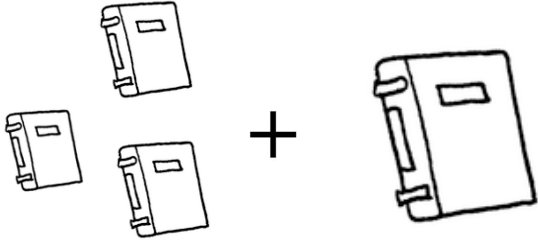
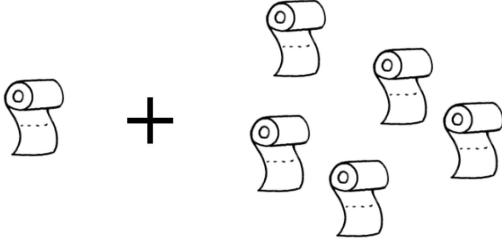
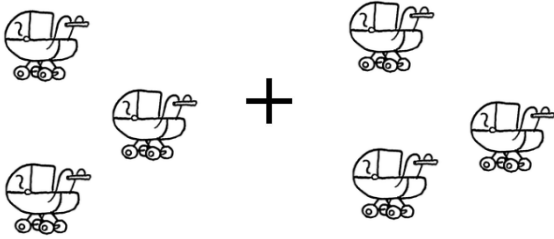
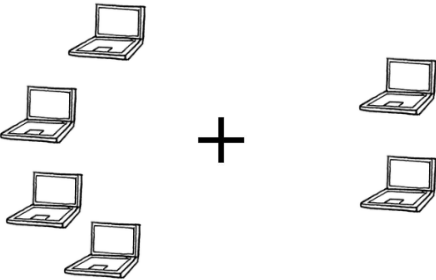
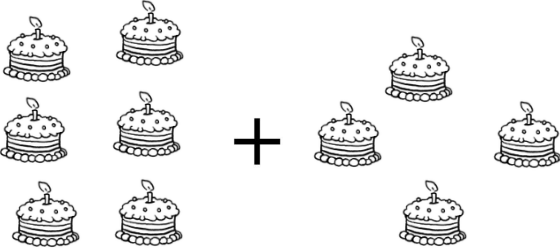
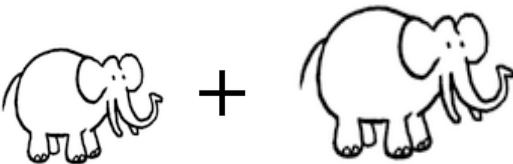
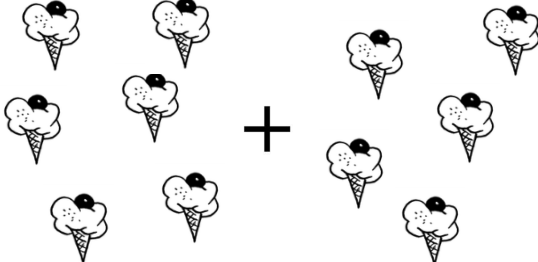
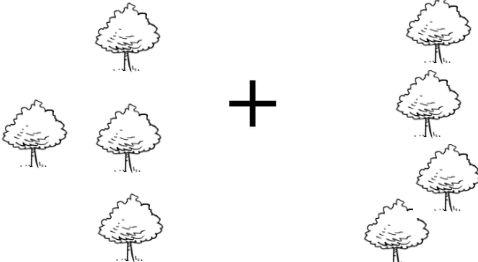
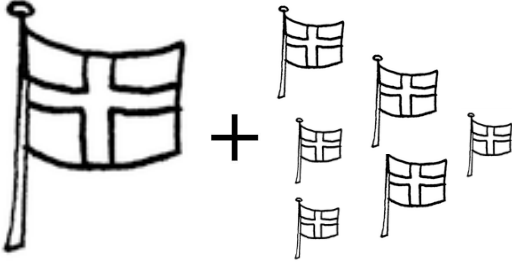

sprogren® M2 – NIVEAU I

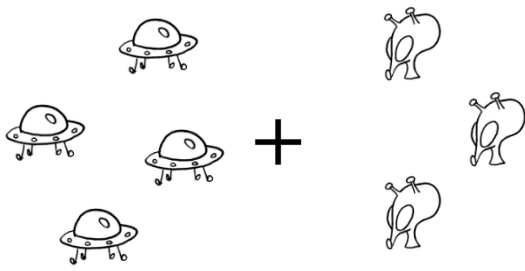
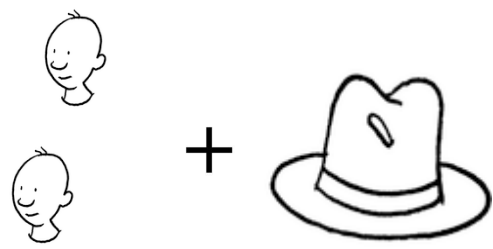
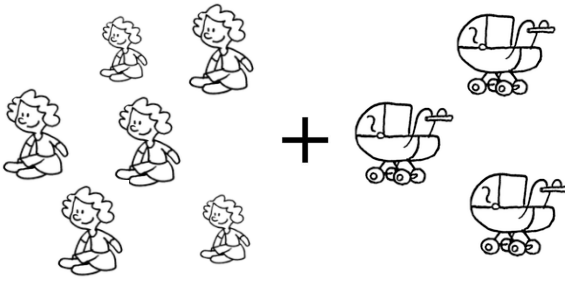
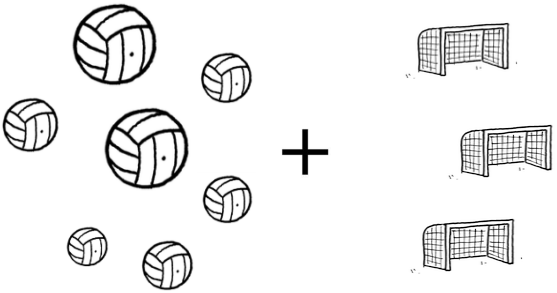
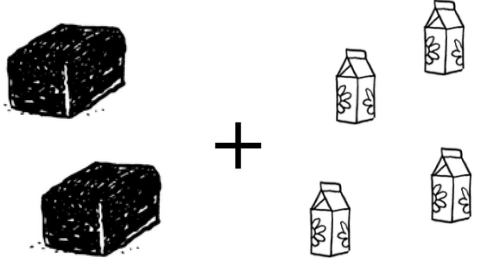
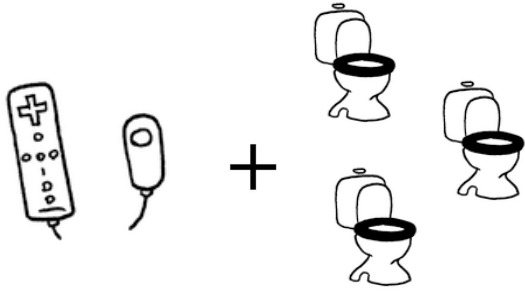
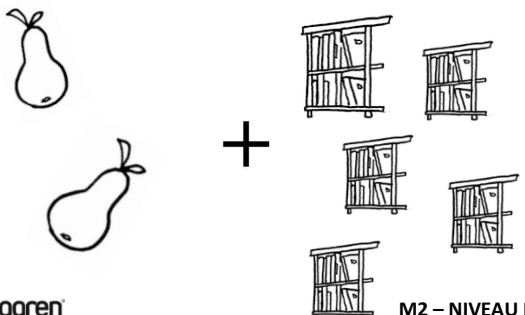
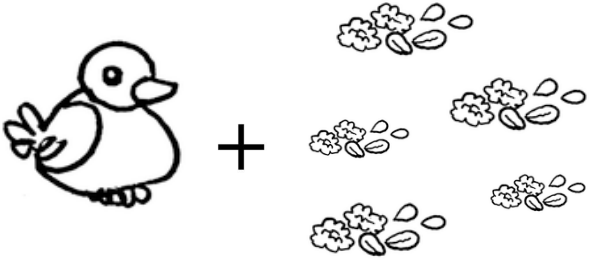
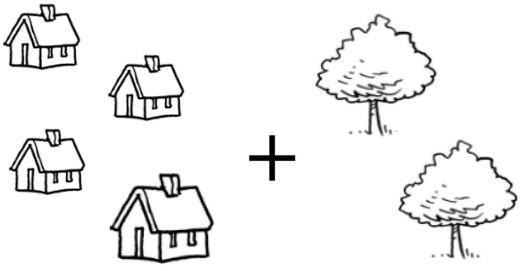
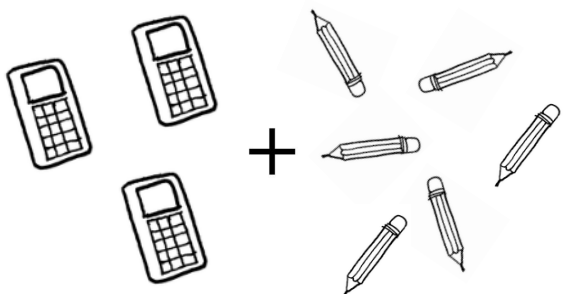
 <p>sprogren® M2 – NIVEAU II</p>	 <p>sprogren® M2 – NIVEAU II</p>
 <p>sprogren® M2 – NIVEAU II</p>	 <p>sprogren® M2 – NIVEAU II</p>
 <p>sprogren® M2 – NIVEAU II</p>	 <p>sprogren® M2 – NIVEAU II</p>
 <p>sprogren® M2 – NIVEAU II</p>	 <p>sprogren® M2 – NIVEAU II</p>
 <p>sprogren® M2 – NIVEAU II</p>	 <p>sprogren® M2 – NIVEAU II</p>

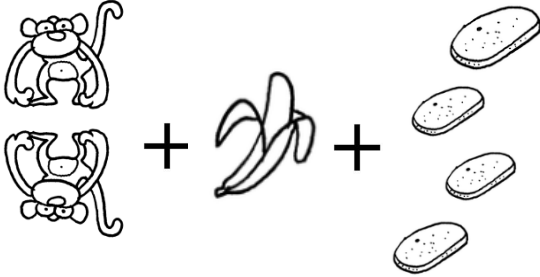
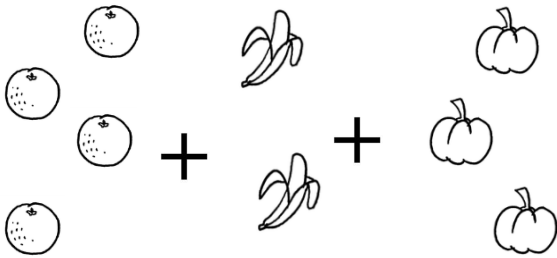
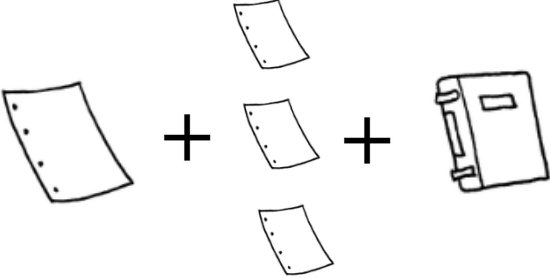
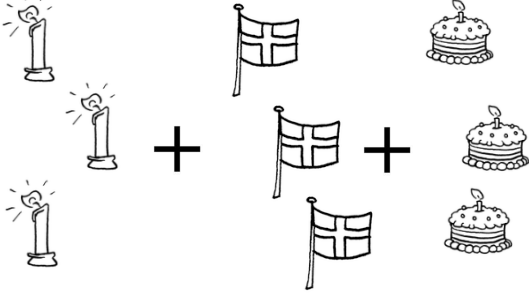
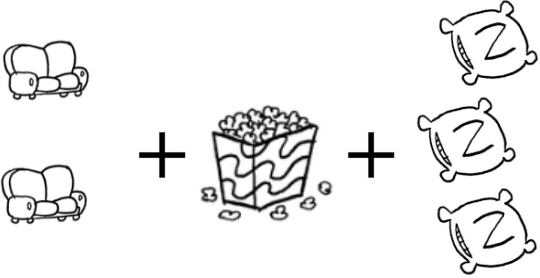
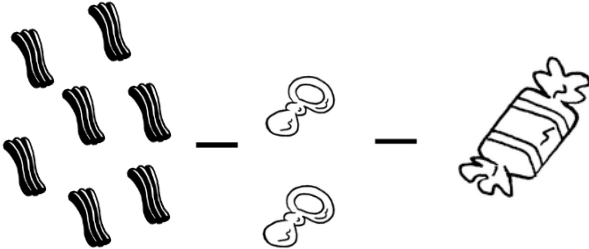
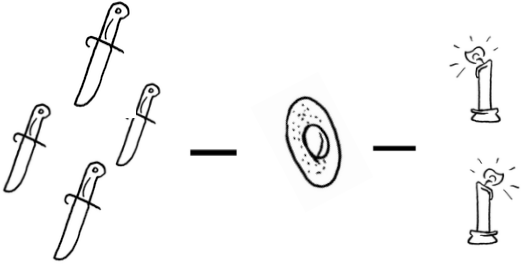
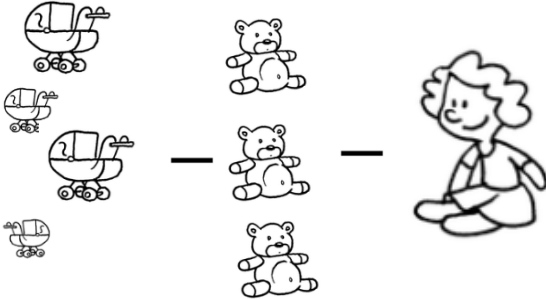
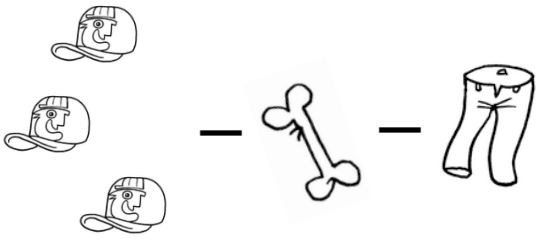
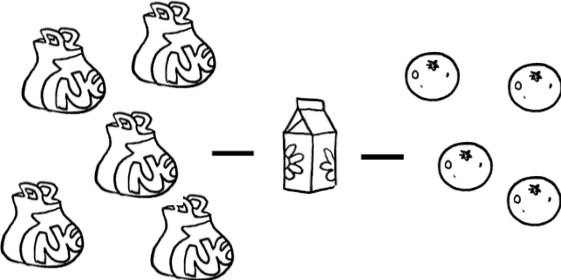
 <p>sprogren®</p> <p>M2 – NIVEAU II</p>	 <p>sprogren®</p> <p>M2 – NIVEAU II</p>
 <p>sprogren®</p> <p>M2 – NIVEAU II</p>	 <p>sprogren®</p> <p>M2 – NIVEAU II</p>
 <p>sprogren®</p> <p>M2 – NIVEAU II</p>	 <p>sprogren®</p> <p>M2 – NIVEAU II</p>
 <p>sprogren®</p> <p>M2 – NIVEAU II</p>	 <p>sprogren®</p> <p>M2 – NIVEAU II</p>
 <p>sprogren®</p> <p>M2 – NIVEAU II</p>	 <p>sprogren®</p> <p>M2 – NIVEAU II</p>

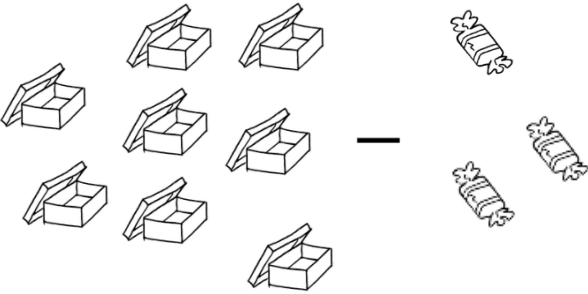
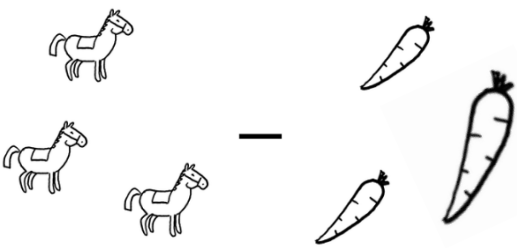
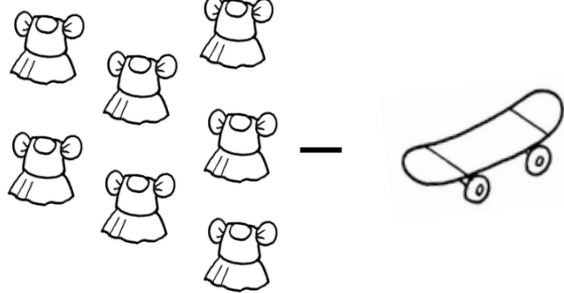
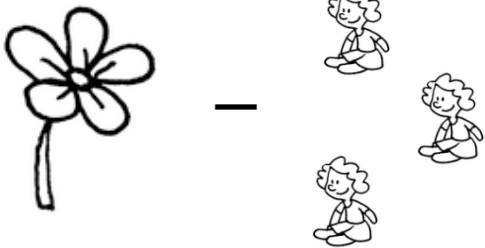
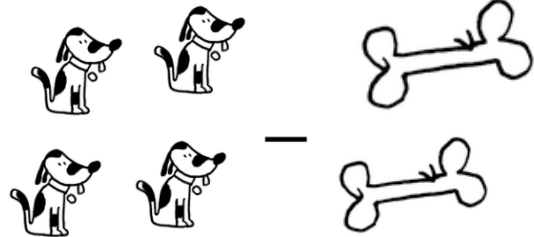
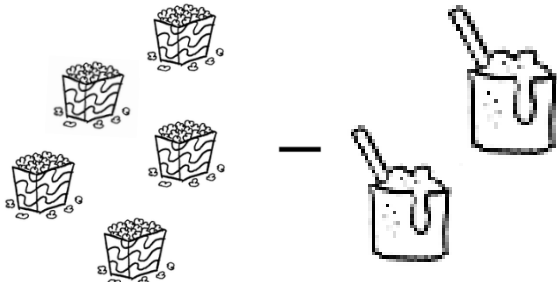
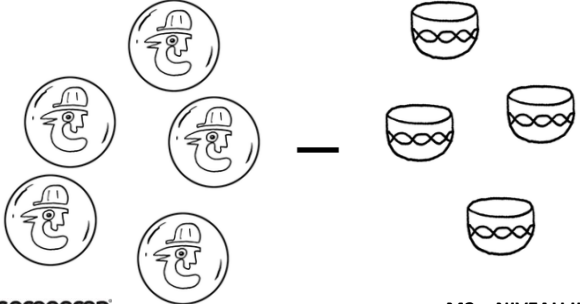
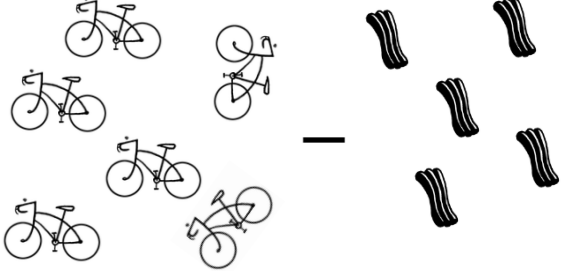
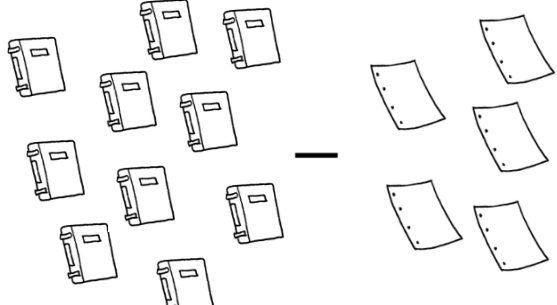
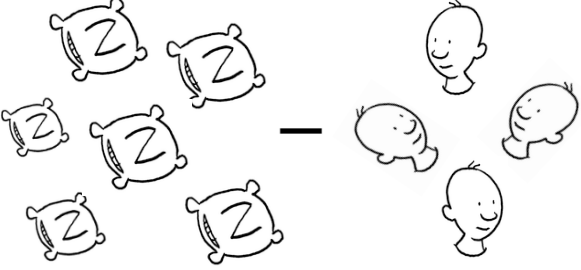
 <p>sprogren®</p> <p>M2 – NIVEAU II</p>	 <p>sprogren®</p> <p>M2 – NIVEAU II</p>
 <p>sprogren®</p> <p>M2 – NIVEAU II</p>	 <p>sprogren®</p> <p>M2 – NIVEAU II</p>
 <p>sprogren®</p> <p>M2 – NIVEAU II</p>	 <p>sprogren®</p> <p>M2 – NIVEAU II</p>
 <p>sprogren®</p> <p>M2 – NIVEAU II</p>	 <p>sprogren®</p> <p>M2 – NIVEAU II</p>
 <p>sprogren®</p> <p>M2 – NIVEAU II</p>	 <p>sprogren®</p> <p>M2 – NIVEAU II</p>

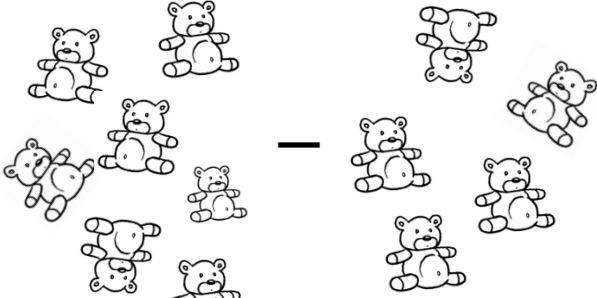
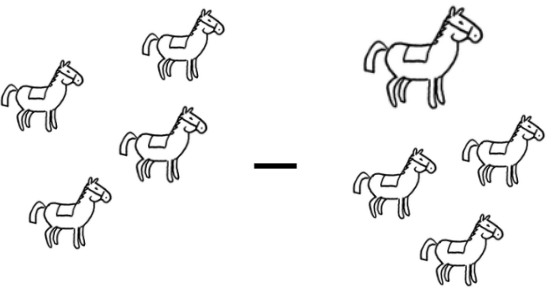
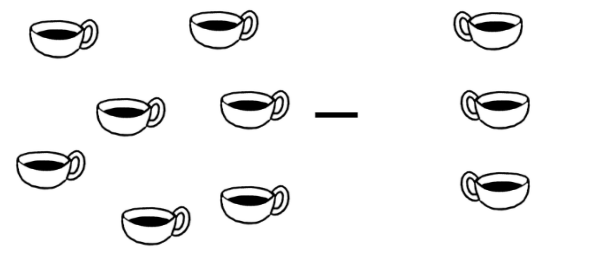
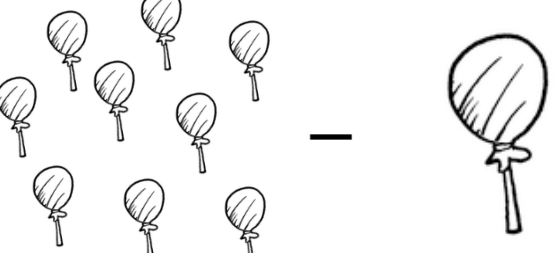
 <p>sprogren® M2 – NIVEAU II</p>	 <p>sprogren® M2 – NIVEAU II</p>
 <p>sprogren® M2 – NIVEAU II</p>	 <p>sprogren® M2 – NIVEAU II</p>
 <p>sprogren® M2 – NIVEAU II</p>	 <p>sprogren® M2 – NIVEAU II</p>
 <p>sprogren® M2 – NIVEAU II</p>	 <p>sprogren® M2 – NIVEAU II</p>
 <p>sprogren® M2 – NIVEAU II</p>	 <p>sprogren® M2 – NIVEAU II</p>

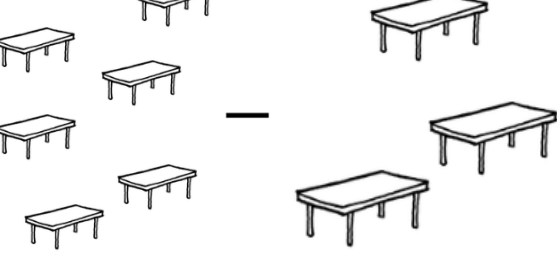
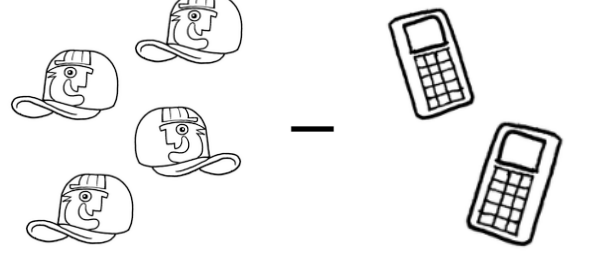
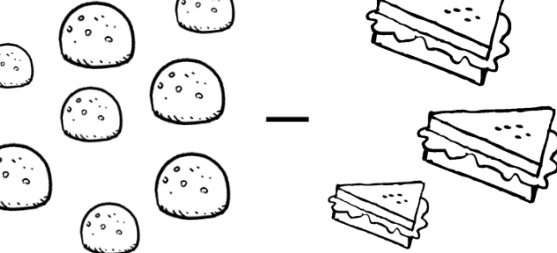
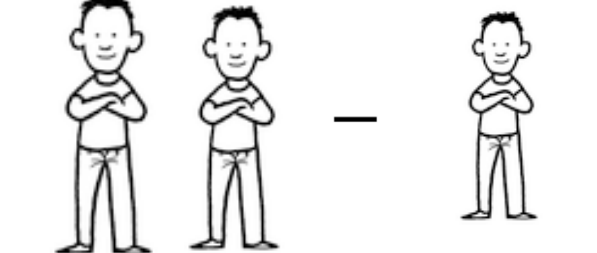
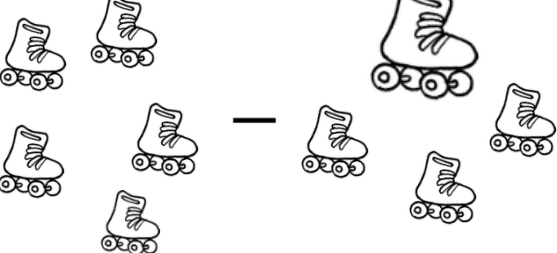
 <p>sprogren® M2 – NIVEAU II</p>	 <p>sprogren® M2 – NIVEAU II</p>
 <p>sprogren® M2 – NIVEAU II</p>	 <p>sprogren® M2 – NIVEAU II</p>
 <p>sprogren® M2 – NIVEAU II</p>	 <p>sprogren® M2 – NIVEAU II</p>
 <p>sprogren® M2 – NIVEAU II</p>	 <p>sprogren® M2 – NIVEAU II</p>
 <p>sprogren® M2 – NIVEAU II</p>	 <p>sprogren® M2 – NIVEAU II</p>

1

2

3

4

5

6

7

8

9

0